

Reinke Operator's Manual

**Pivot and Swing Arm Corner System
with Standard Main Control Panel**

Revision: A

5-2019

P/N: 117829



Table of Contents



System Safety.....	1
Lockout / Tagout.....	2
Restoring Equipment to Service.....	3
Safety Labels.....	6
Standard Panel.....	6
Tower Box.....	7
Tower Base.....	7
Main Control Panel Layout.....	8
System Power Switch.....	8
Water Supply Switch.....	8
End Gun Switch (Optional).....	9
Pressure Switch (Optional).....	9
Park Switch.....	9
Frost Control Switch.....	9
Chemigation / Auxiliary Control Switch.....	9
Generator Switch (Optional).....	10
Direction Switch.....	10
Start Button (Safety Override).....	10
Safety OK Indicator Light.....	10
Percent Timer.....	11
Voltmeter.....	11
Hour Meter.....	11
Main Disconnect Switch.....	11
Auto-Restart (Optional).....	11
Starting the System.....	12
About the Generator.....	13
Primary Settings.....	14
System Speed.....	14
End Gun Settings.....	15
Cam Plate Switches (Optional).....	16
End Gun Switch Ramp.....	16

Part Circle Operations	17
Pivot Center Options	17
Pivot Auto-Stop Option	17
Cam Plate - Pivot Auto-Stop Option	18
Tower Options	18
Tower Auto-Reverse Option	18
Tower Auto-Stop Option	18
Tower Barricade.....	19
Options	21
Disconnecting Spans.....	21
Chemical Injection	22
Chemigation.....	22
Fertigation	23
Insectigation.....	23
Maintenance.....	23
Wheel Gearbox Maintenance	23
Non-Towable Gearboxes	23
Center Drive Gearbox Maintenance.....	24
Three Phase (480 VAC) Center Drive Gearboxes	24
Single Phase (230 VAC) Center Drive Gearboxes.....	24
Initial and Preseason Maintenance	25
Maintenance During Season.....	27
Winterization Procedure	30
Swing Arm Maintenance.....	30
Troubleshooting.....	32

SYSTEM SAFETY

Reinke irrigation systems are designed with many electrical and mechanical safety features. However, each operator must read and understand this and all other accompanying owners manuals for the safe and efficient operation of your Reinke irrigation system. If this system is operated incorrectly, it can pose a safety threat to the operator and others, including serious injury or death. This system is powered by high voltage electricity. Any individual that will be engaging with the system in any way must read and fully understand the contents of this manual. This includes both the basic operation instructions (such as starting, stopping, adjusting water application amounts, and changing directions) as well as the safety obligations noted in this section.

In addition to the operational and safety information provided by this manual, you will also find safety signs and decals located throughout the system itself. For the safest experience possible, make sure you are able to locate and recognize every safety sign and decal located on the system. Throughout this manual, you will find safety information preceded by the words **Caution, Warning, or Danger**. These will be marked with a hazard symbol as shown below. Read each of these warnings closely, as they indicate potential hazards.

 Caution	<p>The Caution sign indicates that a situation, or action, may result in minor damage to property or harm to individuals.</p>
 Warning	<p>The Warning sign indicates that a situation, or action, may result in serious damage to property, injury, or death.</p>
 Danger	<p>The Danger sign indicates that a situation, or action, poses an immediate threat that could result in severe injury or death.</p>

Caution

Make sure you read and understand the operator's manual BEFORE operating, or maintaining, the system. If anything seems unclear, contact your local Reinke dealer.

Ensure that anyone else who operates the system reads and understands the operator's manual.

Follow ALL safety guidelines on the system and in this manual. Please keep in mind that any unauthorized changes made to the system could cause damage to that system.

Danger

DO NOT attempt to perform any maintenance procedures until the Reinke main control panel disconnect switch and all pump and other disconnect switches are locked in the OFF position. Electrical component troubleshooting and replacement should be performed by a certified Reinke Service Technician to ensure built-in safety features remain intact. This also ensures the system remains compliant with the National Electric Code and Reinke Manufacturing specifications. Replace all protective guards and shields before restoring power to the system.

 **Danger**

The movement of an electrically powered, gear-driven, irrigation system is relatively slow. Moving parts are exposed and may present a potential hazard. Therefore, keep all equipment, vehicles, people, livestock, etc. out of the system's path.

DO NOT allow anyone to ride, or climb, on the system unless they are qualified and required to do so for maintenance purposes.

The tower steps have been provided for access to the tower control boxes only. They are not intended for access to the span. For instance, should the sprinkler heads require service, use a ladder to reach them from the ground.

 **Danger**

DO NOT start the system until all electrical equipment has been properly installed and grounded by a qualified electrician. Failing to do so could result in serious injury or death. Ensure that your contractor has grounded the system as required by the National Electrical Code and by all applicable local electrical codes.

When towing a system from field to field, avoid ditches, rough terrain, overhead power lines, etc. The ground wire **MUST** be re-attached to the ground rod, or concrete-encased electrode, and checked for electrical integrity each time the system is towed.

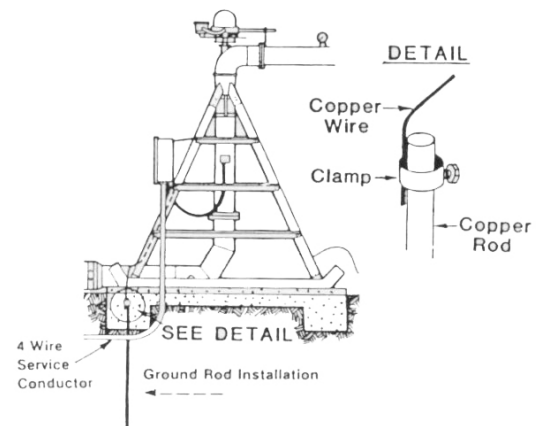

LOCKOUT / TAGOUT

Refer to U.S. Occupational Safety & Health Administration (OSHA) Regulations (Standards - 29 CFR) Typical minimal lockout procedures - 1910.147 App A, or applicable national, state or local regulations, for additional information.

On the following pages, you will find the typical minimal lockout procedures, as according to U.S. Occupational Safety & Health Administration (OSHA) Regulations. This procedure is used whenever maintenance or servicing is done on machines or equipment. It shall be used to ensure that the machine or equipment is stopped, isolated from all potentially hazardous energy sources, and locked out before anyone performs any servicing or maintenance where the unexpected start-up of the machine or equipment, or release of stored energy, could cause injury. When the energy isolating devices are not lockable, tagout may be used. Below is the sequence of Lockout:

1. Notify all affected employees that servicing or maintenance is required on a machine, or equipment, and that the machine, or equipment, must be shut down and locked out to perform the servicing or maintenance.
2. The authorized employee shall refer to the company procedure to identify the type and magnitude of the energy that the machine or equipment utilizes, understand the hazards of the energy, and know the methods to control the energy.
3. If the machine, or equipment, is operating, shut it down by the normal stopping procedure.

4. De-activate the energy isolating device(s).
5. Lock out the energy isolating device(s) with assigned individual locks.
6. Stored or residual energy (such as that in capacitors, springs, elevated system members, rotating fly-wheels, hydraulic systems, air, gas, steam, water pressure, etc.) must be dissipated or restrained by methods such as grounding, repositioning, blocking, bleeding down, etc.
7. Ensure that the system, or equipment, is disconnected from the energy sources by first checking that no personnel are exposed, then verify the isolation of the system, or equipment, by operating the push button or other normal operating controls or by testing to make certain the system, or equipment, will not operate. CAUTION: Return operating controls to the neutral or OFF position after verifying the isolation of the equipment.
8. The system, or equipment, is now locked out.



Restoring Equipment to Service

When the servicing, or maintenance, is completed and the machine, or equipment, is ready to return to normal operating condition, the following steps shall be taken.

1. Check the machine, or equipment, and the immediate area around the machine to ensure that nonessential items have been removed and that the machine, or equipment, components are operationally intact.
2. Check the work area to ensure that all employees have been safely positioned or removed from the area.
3. Verify that the controls are in neutral.
4. Remove the lockout devices and reenergize the machine or equipment. Note: The removal of some forms of blocking may require reenergization of the machine before safe removal.
5. Notify affected employees that the servicing, or maintenance, is completed and the machine, or equipment, is ready for use.

“UNITED STATES DEPARTMENT OF LABOR.” Occupational Safety and Health Administration (1996). *Occupational Safety and Health Standards: General Environmental Controls*, (Standard No. 1910.147 App A). Retrieved from www.osha.gov/pls/oshaweb/owadisp.show_document?p_table=STANDARDS&p_id=9805.



Exercise caution when handling fuel near systems equipped with combustion engine-driven generators and pumps.



Keep away from the system during thunderstorms or other severe weather conditions. The system is grounded and is probably the highest object in the field, making it a good lightning receptor.

**Danger**

Be sure protective guards are installed on all belts and driveshafts of ancillary equipment such as combustion engines, electric motors, pumps, etc.

**Danger**

If you suspect a short circuit, or the system is not working correctly, DO NOT touch the system and keep others away from it. Call your Reinke service technician. Electrical component troubleshooting and replacement should be performed by a certified Reinke Service Technician to ensure built-in safety features remain intact. This also ensures the system remains compliant with the National Electric Code and Reinke Manufacturing Specifications.

**Danger**

Avoid any bodily contact with high pressure water streams from sprinklers and end guns.

**Caution**

Do not operate the system with water when temperatures are below 40°F (4.5°C). This can cause structural damage to the system. Damage from freeze-up is not covered under warranty.

**Warning**

Keep away from fields where the system is chemigating. Make sure the applied chemical and water does not blow or drift past the area of intended operation. A check valve must be installed between the pivot center and the pump to prevent the mixture of water and chemical from siphoning back into the irrigation water source. Comply with all local, state, and federal regulations.

**Caution**

Maintain adequate crop clearance. Allowing the systems trussing to drag in the crop, can cause structural damage to the system.

**Caution**

DO NOT oversize fuses. Fuses are sized for a specific circuit. It is very important to make sure you have the proper fuse size in place before initially starting the system and when replacing fuses.

 **Caution**

In most states, it is unlawful to spray water on state and county roadways. This is a serious hazard and must not be allowed.

 **Warning**

If your system is equipped with any auto-stop or auto-reverse mechanism, make sure they are working correctly and a tower barricade is properly installed. ***Reinke disclaims any and all liability (including any liability created pursuant to the Irrigation Systems Warranty) with regard to damage to the irrigation system, or to other property, or personal injury or death, caused by improper installation or maintenance of Reinke-supplied tower auto-reverse or auto-stop switches or tower barricades, or by use of customer-supplied barricades.***

 **Danger**

Drive shafts may start without warning. Keep away from drive shafts to prevent clothing or limbs from being entangled, resulting in severe injury.

 **Caution**

Safe operation of any mechanized irrigation system is the responsibility of the operator, regardless of utilizing either on-system or remote control.

This manual was developed based on the information that was available at the time it was written. Reinke reserves the right to update this information, at any time, without providing prior notice.

SAFETY LABELS

The following safety signs and decals can be found on your system as indicated below. Make sure that you can locate and identify each of these. If these labels become illegible at any time, contact your Reinke dealer to order replacements.

STANDARD PANEL

Operating Instructions

⚠️ **Before starting System, each operator must read and understand all Reinke and supporting equipment owners manuals.**

1. Observe field and System conditions to be sure the System and System's path are clear of people and any other obstacles. See "System Safety" section at the beginning of appropriate Reinke System Owners Manual.
2. If you desire to run water with the System, ensure Electric Pump Control is enabled and safe to start as per Pump Manufacturer's recommendations. Then turn Pump Disconnect Switch to the "ON" position.
3. If your System utilizes an optional Generator Switch to control a Combustion Engine Driven Well or Generator, turn the Generator Switch to the "START" position. Ensure Engine is safe to start as per Engine Manufacturer's recommendations. Then start Engine as per Engine Manufacturer's recommendations.
4. Turn Main Disconnect Switch to the "ON" position.
5. Observe the voltage on the Main Control Panel Voltmeter. This meter should read 456-504 VAC, 60 HZ (380-420 VAC, 50 HZ). In no event should the operational voltage read below 456 VAC or above 504 VAC.
6. Ensure "Safety OK" Indicator Light is lit up. If it is not lit up, the Safety Circuit is open. See "Safety OK Indicator Light" in the "Main Control Panel Layout" section of appropriate Reinke System Owners Manual.
7. Turn System Power Switch to the "ON" position.
8. Turn Water Supply Switch to the "ON" position if you desire to run water with the System. Turn Water Supply Switch to the "OFF" position if you do not desire to run water with the System.
9. If your System is equipped with an optional Low Pressure Shut Down, turn the Pressure Override Switch to the "BYPASS" position.
10. If your system is equipped with the optional Auto-Stop Cam Plate Option, it may be necessary to turn the Park Override Switch to the "BYPASS" position until the System moves off the Auto-Stop Ramp. See "Cam Plate Switches" section in appropriate System Owners Manual.
11. If your System is equipped with the optional Low Temperature (Frost) Shutdown kit, turn the switch to the "BYPASS" position if you desire to move the System without pumping water through it at temperatures below 45°F. Turn the switch to the "AUTO" position for normal operation. This will ensure the System will shut down if the temperature falls below the temperature set on the Frost Control Board on the Back Plate of the Main Control Panel. In no case should the System be operated with water in potential icing conditions.
12. Set ATC Timer to desired speed. See Speed Chart in Main Control Panel or "Speed Chart" Section in appropriate Reinke System Owners Manual.
13. Turn Direction Switch to desired direction. "FORWARD" = Clockwise and "REVERSE" = Counterclockwise.
14. Push Start Button and hold for three (3) seconds or less. You should hear the magnetic Contactor engage (snap) and the System should start. If not, recheck this procedure to make sure you have followed it correctly. Release the button. If another snap is heard, a Malfunction is indicated. See "Start Button" in the "Main Control Panel Layout" section of appropriate Reinke System Owners Manual. **Do not hold the Start Button in for more than three (3) seconds as this will override the safety circuits.**
15. If your System is equipped with an optional Low Pressure Shut Down, turn the Pressure Override Switch to "AUTO."
16. If your System utilizes an optional Generator Switch to control a Combustion Engine Driven Well or Generator, turn the Generator Switch to "RUN."
17. If your System is interlinked with a Chemigation Pump or other auxiliary device, turn the Chemigation/Auxiliary Switch to "ON."
18. If your System is equipped with an optional End Gun, turn the End Gun Switch to "RUN" if you desire to operate the End Gun. Turn the switch to "STOP" if you do not desire to operate the End Gun.
19. If your system is equipped with the optional Auto-Stop Cam Plate Option, and you desire to park the System, set Auto-Stop Ramp to desired location and turn Park Override Switch to the "AUTO" position. See "Cam Plate Switches" section in appropriate System Owners Manual.

Reinke P/N 11884

Operating instructions and the operator's manual can be found on the inner door of the panel.

⚡ DANGER / PELIGRO

480 VOLTS / 480 VOLTIOS

This machine may start automatically. Do not open panel or service machine until machine disconnect is in OFF position and locked.

Esta máquina puede arrancar automáticamente. No abrir el panel ó haga servicio hasta que el interruptor principal -en el panel- esté en posición de OFF.

Cette machine peut démarrer automatiquement. Ne pas ouvrir l'armoire de contrôle ou faire l'entretien de la machine avant que le bouton de déconnexion ne soit en position OFF et verrouillé.

IMPORTANT

START BUTTON OVERRIDES SAFETY CIRCUIT HOLDING BUTTON IN FOR MORE THAN 3 SECONDS COULD DAMAGE SYSTEM

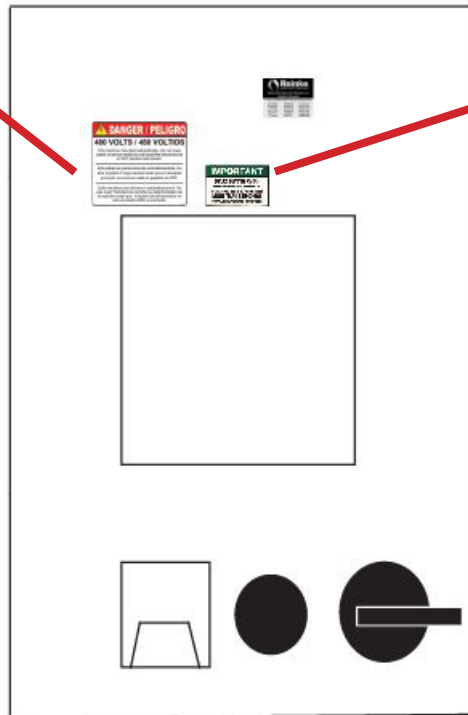

This caution label is found on the bottom of the panel.

CAUTION

IRRIGATION MACHINES AND EQUIPMENT MUST HAVE FOUR WIRES FROM THE LOAD SIDE OF THE POWER SOURCE TO THIS DISCONNECT. (GENERATORS INCLUDED)
ARTICLE 675 AND 250-61 --- NATIONAL ELECTRICAL CODE

TOWER BOX

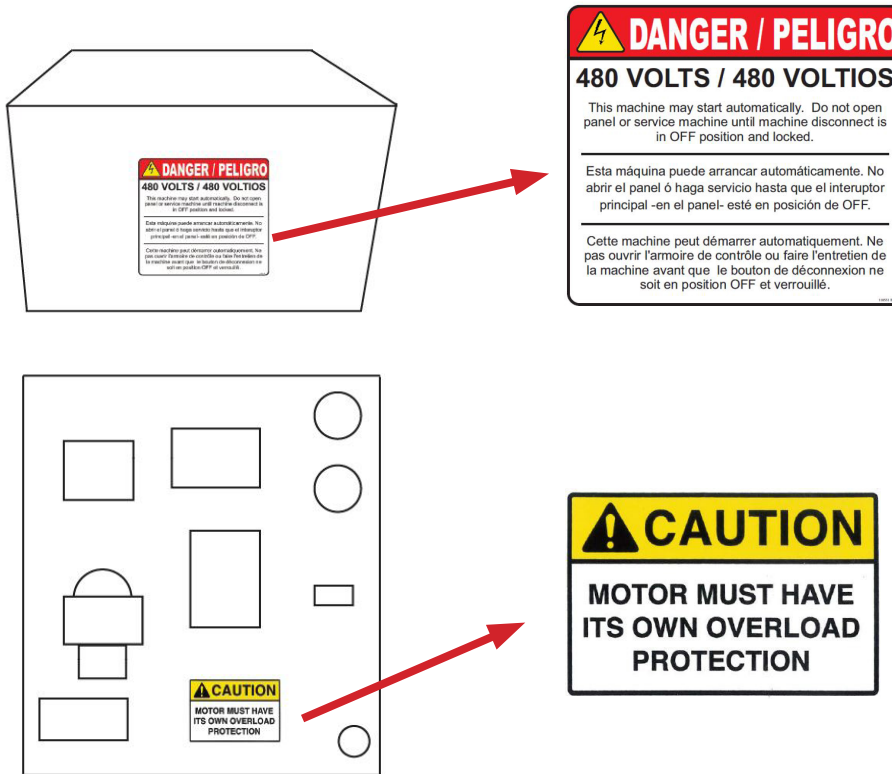

TOWER BASE

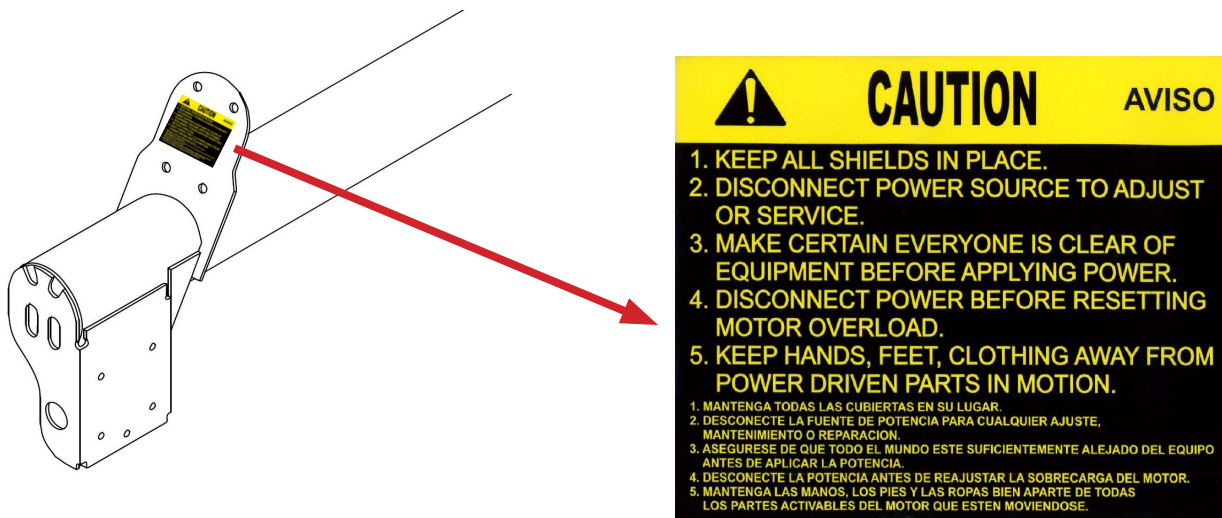

MAIN CONTROL PANEL LAYOUT

The main control panel contains the necessary controls to direct the operation of the system. Opening the panel cover door will reveal the controls detailed in the following pages of this manual. Controls will be described in this section starting with the System Power Switch and moving counter-clockwise.

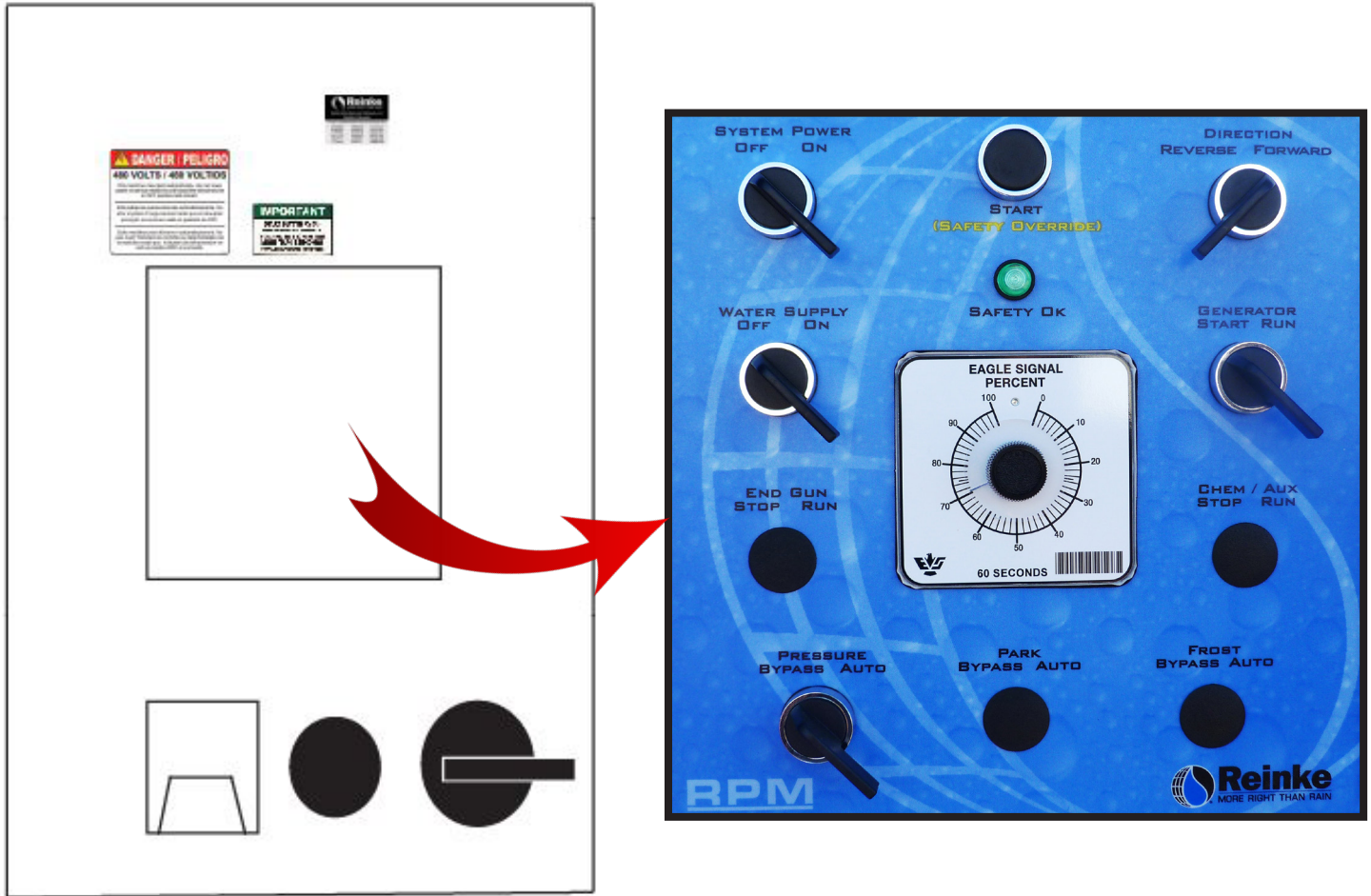

System Power Switch

The system power switch must be in the ON position for the system to operate in either direction. When the switch is in the OFF position, the system will not operate. Place the switch in the OFF position to shut down the system.

Water Supply Switch

The water supply switch breaks the well kill circuit and allows the system to operate without the pump on for commercial utility powered systems. When the switch is placed in the OFF position, the well kill circuit is open and the pump will not start when the system is started. When the switch is placed in the ON position, the well kill circuit is closed and the pump will start when the system is started. For generator systems, always leave the water supply switch ON.

End Gun Switch (Optional)

If your system is equipped with an optional end gun, a two-position override switch labeled STOP/RUN will be located on the main control panel. Turn the end gun switch to RUN to operate the end gun. Turn the switch to STOP to turn the end gun off. See page 15 for controlling end guns.

Pressure Switch (Optional)

If your system is equipped with an optional low pressure shutdown, a two-position switch labeled BYPASS/AUTO will be included on the main control panel. In the BYPASS position, the pressure switch is bypassed. Use this position when you start the system or want to move the system without supplying water to it. In the AUTO position, the pressure switch is activated and the system will shut down if the pressure falls below the preset level. Be sure the switch is in the AUTO position after pressure has built in the system. This assures proper function of the switch during water application and normal operation.

Park Switch

If your system is equipped with an optional cam plate auto-stop (park) switch, a two-position override switch labeled BYPASS/AUTO will be located on the main control panel. Turn the park override switch to the BYPASS position if you would like the auto-stop switch bypassed. This means the system will not stop when the auto-stop switch is activated. In the AUTO position, the system will shut down when the cam plate auto-stop switch is activated. If your system is equipped with the optional auto-stop cam plate option, it may be necessary to turn the park override switch to the BYPASS position until the system moves off the auto-stop ramp. See page 16 for controlling cam plate auto-stop switches.

Frost Control Switch

If the system is equipped with the optional low temperature shutdown kit, a two-position override switch labeled BYPASS/AUTO will also be on the main control panel front. In the BYPASS position, the temperature sensing switch is bypassed. Use the BYPASS position to move the system without pumping water through it at temperatures below 45° F. In the AUTO position, the system will shut down if the temperature falls below the temperatures set on the frost control board. The frost control board is located on the back plate of the main control panel. Be sure the switch is in the AUTO position during normal operation. At no time, should the system be operated with water in potential icing conditions.

Chemigation / Auxiliary Control Switch

Systems equipped with chemigation, or fertigation, and a standard main control panel will have this switch. It is used to manually turn on and off the chemigation or fertigation 120V or 480V pump.

Generator Switch (Optional)

If the system is equipped with an engine-driven generator or pump, the generator switch is used to bypass the engine shutdown during start up. The START position is used when starting the engine. Then the switch is turned to RUN after the system is running.

 **Caution** *If the generator switch is left in the START position, the engine shut-down is bypassed and the engine will not kill in the event the system stops.*

Direction Switch

This switch is used to select the systems direction of operation. To run the system clockwise, the switch must be placed in the FORWARD position before pressing the START button. To run the system counter-clockwise, the switch must be placed in the REVERSE position before pressing the START button. To change the systems direction, simply move the direction switch to the FORWARD or REVERSE position and press the START button. To enable auto-reverse (optional), place the direction switch in the AUTO position and press the START button. When in auto, the system will start in the direction it was last moving. Refer to the tower auto-reverse switch on pages 18-19 for more information.

Start Button (Safety Override)

After the direction switch has been placed in the FORWARD, REVERSE, or AUTO positions, start the system by pressing the start button. This activates the magnetic contactor in the main control panel. The contactor “latches” if all safety circuits indicate they are in a closed position. Listen for the contactor to engage when the start button is pressed. If, after the button is released, another “thump” is heard, the contactor did not stay engaged (latched) and the system will not continue to run. This indicates the safety circuit has an “open” or “no go” condition that needs correcting.

 **Warning** *DO NOT hold the start button in for more than three (3) seconds as this will override the safety circuits. Call your Reinke dealer or authorized service person for assistance.*

Safety OK Indicator Light

The Safety OK Indicator Light will illuminate when the safety circuit is complete and the system is running. If the safety circuit is open, the problem must be corrected before the system can safely start. One reason for a “no go” safety circuit could be a stuck tower that has caused misalignment. Call your Reinke dealer or authorized service person for assistance.

Percent Timer

The rate the system travels around the field is controlled by a percent timer, intermittently engaging the last tower gear drive motors. The timer is based on a 60-second cycle. For example, if the percent timer is set at 50%, then the last tower will run for 30 seconds, off for 30 seconds, then back on for 30 seconds, etc. 100% provides continuous end tower movement, the maximum speed. The lower the percent timer setting, the slower the last tower will move and the longer it takes to move the system around the field.



Voltmeter

This meter monitors the voltage between two incoming legs of the supplied power. This meter should read 456-504 VAC, 60 HZ (380-420 VAC, 50 HZ) on 480 VAC systems, or 230-250 VAC, 60 HZ on 240 VAC systems. At no time should the operational voltage read outside these parameters.



Hour Meter

This meter displays the number of hours the system has operated (excluding the pump) since it was new.



Main Disconnect Switch

The main disconnect switch controls the 480 or 240 VAC power supply to the system. The switch is mounted on the back plate of the main control panel and is interlocked with a disconnect handle on the main control panel inner door. The switch must be in the ON position for the system to operate. To open the inner panel door and view the inside of the control panel, place the disconnect switch in the OFF position. Do not turn the main disconnect switch to the ON position with the inner door open.



Auto-Restart (Optional)

If your system is equipped with auto-restart, the system can be adjusted to automatically restart up to 5 minutes after the interrupted power has been restored to the main control panel. If the 480 or 240 VAC power to the system is interrupted and then restored, always turn the system power to the OFF position to prevent unwanted starts.



Danger *Systems equipped with the auto-restart option, may restart unexpectedly!*

STARTING THE SYSTEM

If the system has just been installed, the generator (or its direction of rotation) been changed, or the power service has been worked on or changed; have your service person check the system for proper phasing. Knowing the functions of the various controls in the main control panel is necessary for the operation of your irrigation system. The system is electrically connected to your water supply so that if one fails, the other will shut down. For this reason, you must coordinate the operation of the water supply and the system controls. The following procedures are for typical installations. If your installation is other than typical, consult your Reinke dealer or service person. See pages 17-23 for instructions on optional equipment.

1. Observe field and system conditions to be sure the system and system's path are clear of people and obstacles. See "System Safety" section at the beginning of this manual for more information.
2. If you want to run water with the system, ensure the electric pump control is enabled and safe to start as recommended by your pump manufacturer. Then turn the pump panel disconnect switch to the ON position.
3. If your system utilizes an optional generator switch to control a combustion engine-driven well and/or generator, turn the generator switch to the START position. Start the engine following all engine manufacturer's safety and operating instructions.
4. Turn the main disconnect switch to the ON position.
5. Observe the voltage on the main control panel voltmeter. This meter should read 456-504 VAC, 60 HZ (380-420 VAC, 50 HZ) on 480 VAC systems or 230-250 VAC, 60 HZ on 240 VAC systems. At no time, should the operational voltage read outside these parameters.
6. Turn the system power switch to the ON position.
7. Turn the water supply switch to the ON position if you want to run water with the system. Turn the water supply switch to the OFF position if the system is to run dry.
8. If the system is equipped with an optional low pressure shut down, turn the pressure override switch to the BYPASS position.
9. When the system is equipped with the optional auto-stop cam plate option, it may be necessary to turn the park override switch to the BYPASS position until the system moves off the auto-stop ramp. See "cam plate switches" on page 16.
10. If the system is equipped with the optional low temperature (frost) shutdown kit, turn the switch to the AUTO position for normal operation. This will ensure the system will shut down if the temperature falls below the temperature set on the frost control board on the back plate of the main control panel. At no time, should the system be operated with water in potential icing conditions. Set the switch to the BYPASS position if you want to move the system without pumping water through it at temperatures below 45°F.

11. Set the percent timer to the desired speed. See the speed chart in the main control panel or on page 14.
12. Turn the direction switch to the desired direction. FORWARD = Clockwise and REVERSE = Counterclockwise. See "Direction Switch" on page 10.
13. Push the start button and hold for three (3) seconds or less. You should hear the magnetic contactor engage (snap) and the system should start. If not, repeat step 14 and release the button. If another snap is heard, a malfunction is indicated. See "Start Button" on page 10. Do not hold the start button in for more than three (3) seconds as this will override the safety circuits.
14. If the system is equipped with an optional low pressure shut down: once the system has reached operating pressure, turn the pressure override switch to the AUTO position.
15. When the system utilizes an optional generator switch to control a combustion engine-driven well or generator, turn the generator switch to the RUN position.
16. If the system is interlinked with a chemigation pump or other auxiliary device, turn the chemigation/auxiliary switch to the ON position.
17. When the system is equipped with an optional end gun, turn the end gun switch to RUN if you desire to operate the end gun automatically. Turn the switch to the STOP position if you do not desire to operate the end gun.
18. If your system is equipped with the optional auto-stop cam plate option, and you desire to park the system, set the auto-stop ramp to the desired location and turn the "Park Override Switch" to the AUTO position. See "Cam Plate Switches" on page 18.

About the Generator

Reinke Manufacturing Co., Inc. supplies compact generator models that are a suitable source of electrical power for an irrigation system. The generator is normally driven from the same engine as the well pump. The drive consists of a double v-belt arrangement. The generator can be mounted near the engine regardless of whether the engine is trailer-mounted or secured to a concrete base.

The generator voltage is controlled by the engine speed. The voltage should not fall below 456 or go above 504 Volts. This should correspond to a generator RPM of 1750 to 1825. The generator RPM for 60 HZ output is 1800 (1500 RPM for 50HZ output). At no time, should the operational voltage read in excess of +5%. The generator pulley may initially be rotated either direction to generate power.

 **Caution** *If the generator rotation is ever reversed later, the system will be out-of-phase. Call your Reinke dealer or service person to correct the phasing problem if you plan to operate the generator while rotating it in the opposite direction.*

NOTE: The generator warranty requires that all combustion engines coupled to a generator, driving the system, must have a governor, a tachometer, and a safety load meter. The generator and system controls will be damaged by over, or under, engine speeding.

PRIMARY SETTINGS

System Speed

A speed chart with an adhesive back is provided with each system. The information given on the chart has been specifically calculated for each particular installation. Two sets of numbers are given on this chart: the percent timer setting for various application amounts and the time it takes to complete one revolution at these settings. Place the sticker on the main control panel front where it can be referenced in the future.

		Reinke Manufacturing Co. Inc. 101 Reinke Road P.O. Box 166 Deshler, Nebraska 68340 USA (402) 365-7251 www.reinke.com	
System Serial No:		System Flowrate (gpm):	
Owner's Name:		System Press. (psi):	
End (H) Tower Tire Size:		(H) Center Drive Gear Ratio:	
		(H) Speed @ 100% (fpm)	
		End Gun Model No:	
Water Application Depth (in):			
Percent Timer Setting 60 Hz.:		100%	
Application Duration (hr : min):			
End Gun Trip Adjustment:		1/4 inch at the cam wheel is equivalent to feet at the end of the system.	

The speed chart has been calculated for ideal conditions. Actual conditions may vary from chart accuracy. When the system is used to apply fertilizer or pesticides, a high level of accuracy is desired. The operator can calculate speed chart data based on the actual performance of the system. Ask your Reinke dealer representative for assistance calculating the actual rotation time and the correct percent timer setting before you start.

The percent timer setting can be calculated using the following formula:

$$\% = \frac{GPM \times 320 \times W}{D \times L \times L \times S}$$

Where:

- GPM = Gallons per minute supplied to the pivot.
- W = Distance from the pivot to the end wheel track in feet.
- D = Desired depth of water to be applied in inches.
- L = Length of the system coverage in feet.
- S = Speed of end tower in feet per minute.

“L”

LENGTH OF THE SYSTEM

In most cases, the length of the system coverage varies because end gun sprinkler(s) are used in the corners only. Therefore, using an “L” value equal to the average coverage length will give the best results.

“S”

GROUND TRAVEL SPEED

Ground travel speed is measured in feet per minute.

End Gun Settings

Caution

In most states, it is unlawful to spray water on state and county roadways. This is a serious hazard and must not be allowed.

The end gun switch is the bottom switch on the cam wheel mounting plate. It utilizes a 90-degree increment switch and is activated by an 8-prong actuator contacting a movable clamp-on trip on the cam wheel. Line up the 45 degree prong of the 8-prong actuator so that it hits the center of the clamp-on trip thumbscrew. When the green bar of the 8-prong actuator is in the horizontal position, the switch is ON. When the red bar of the 8-prong actuator is horizontal, the switch is OFF. To activate the end gun, place a clamp-on trip on the cam wheel so it turns the 8-prong actuator. Make sure the end gun is properly set to the arc settings below, before installing the clamp-on trip on the cam wheel. Install the next clamp-on trip on the cam wheel when the end gun starts to reach its boundaries. Repeat this procedure in each of the corners where you desire to operate the end gun.

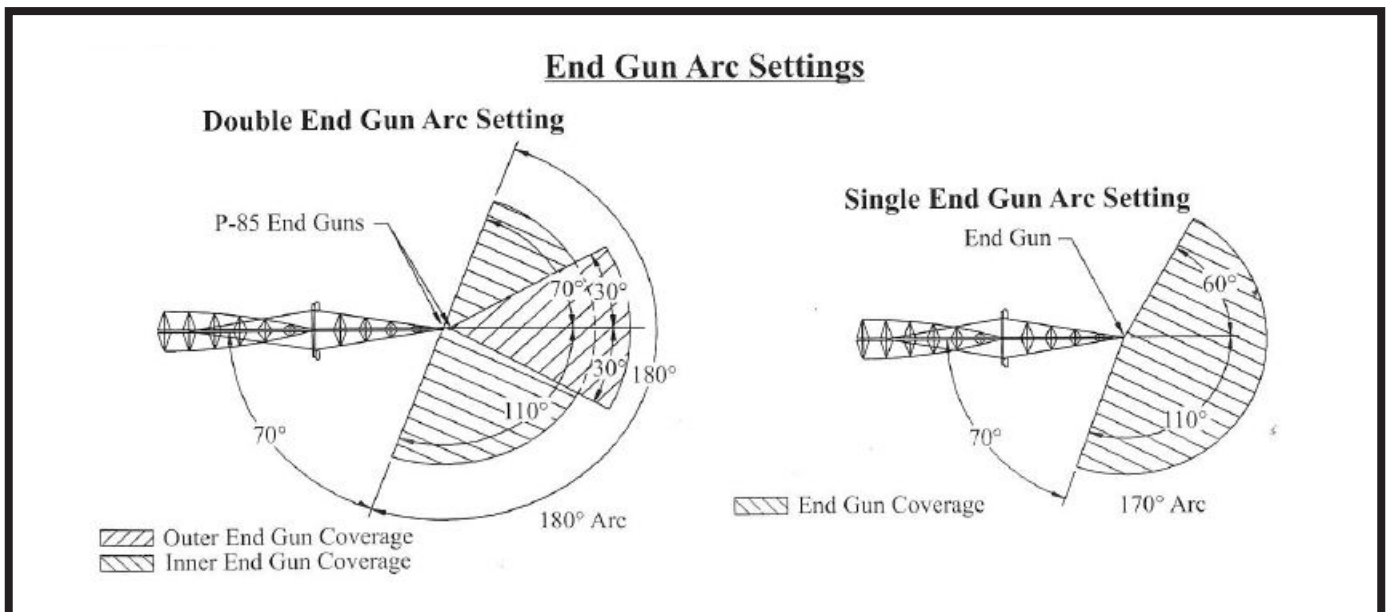
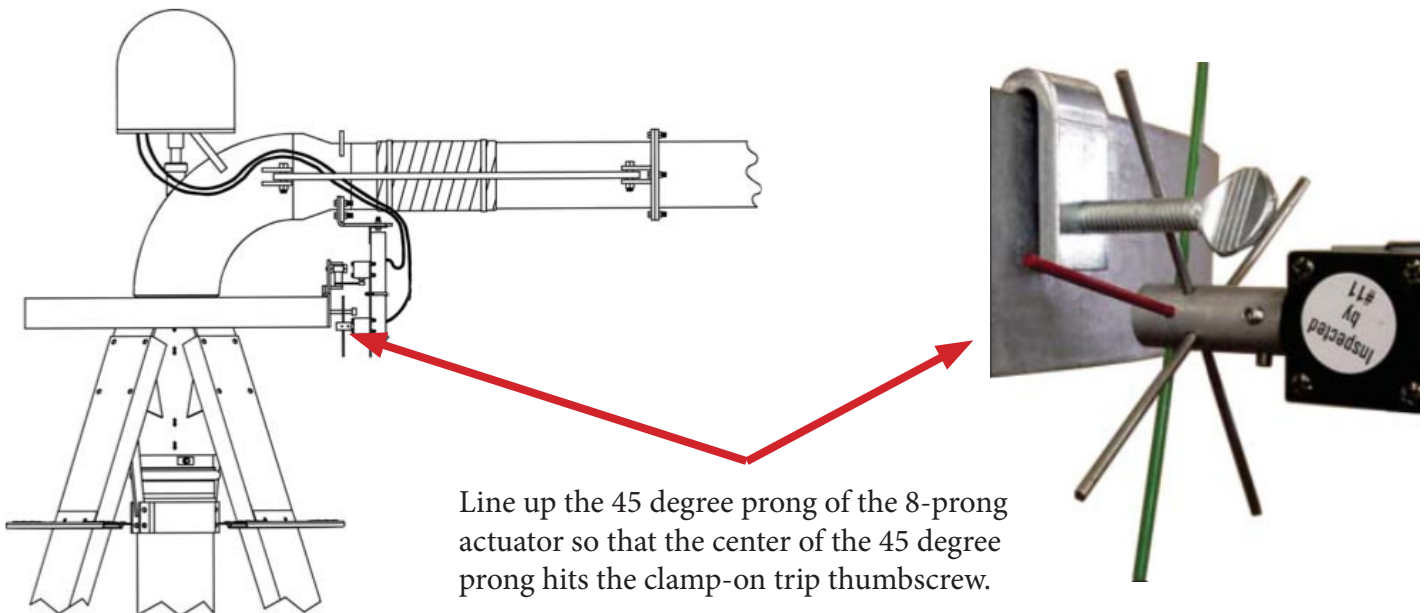

Cam Plate Switches (Optional)

Reinke Manufacturing also has an optional cam plate switch assembly for end gun control. This is an alternative to the traditional Reinke cam wheel switch assembly.

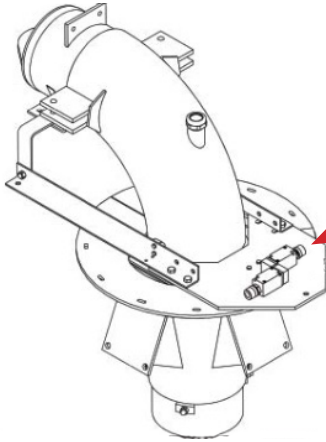

The end gun switch is a plunger switch activated by rubber ramps located on top of the cam plate. See the illustration here for details.

End Gun Switch Ramp

The end gun switch ramps fit onto a metal retainer plate bolted to the cam plate. Place the ramp so the end gun plunger switch contacts the ramp where the end gun is to be activated and the end gun plunger switch exits the ramp where the end gun is to be deactivated. The ramp may have to be trimmed to achieve the desired area. Make sure the end gun is properly set to the arc settings on the previous page.

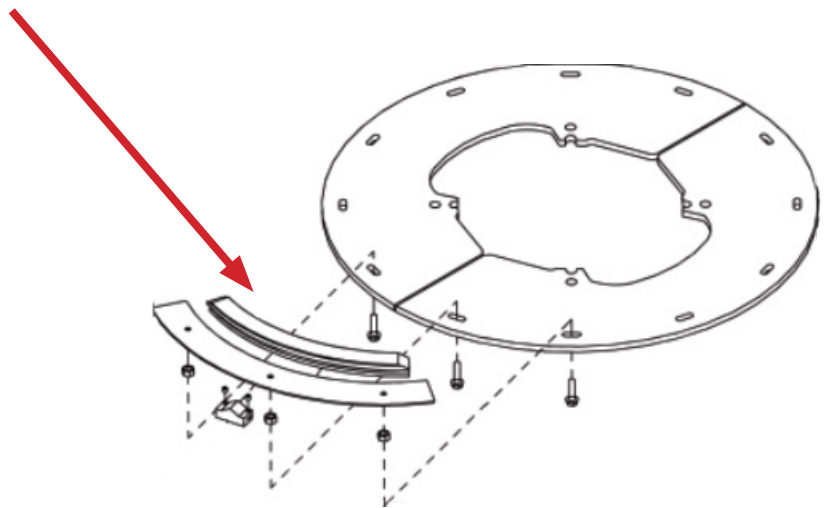

PART CIRCLE OPERATIONS

Part circle systems require safeguards to make sure the system doesn't go beyond desired boundaries. There are options to either stop, or automatically reverse, the system when it reaches the end of the run. These mechanical control options are either located at the pivot center or on a tower. **All part circle systems require a physical barricade to constrain the system in the event of a control failure.**

Disclaimer

Reinke disclaims any and all liability (including any liability created pursuant to the Irrigation Systems Warranty) with regard to damage to the irrigation system, or to other property, or personal injury or death, caused by improper installation or maintenance of Reinke-supplied auto-reverse or auto-stop switches or tower barricades, or by use of customer-supplied barricades.

 **Warning** *All auto-stop and auto-reverse devices require the use of a barricade in the tower wheel track. The barricade should extend to the inside of the track to accommodate possible movement of the tower. The system may become shorter due to misalignment, but it cannot grow longer. See the barricade drawings on page 19.*

Pivot Center Options

Before starting the system, check the cam or trips and make sure they are in the desired position. When initially starting the system, make a point of being nearby when the switches are due to trip. This could prevent a catastrophe if a trip is located in the wrong position on the cam wheel or cam plate.

Pivot Auto-Stop Option

The auto-stop switch is the top switch on the switch mounting plate. This switch has a wide trip arm with a roller on the end. The heads of the auto-stop switch have a momentary contact. This allows the switch to trip from side to side and return to the center position. The auto-stop trip is a short arm with a flap attached to it. A pin on the bottom stops the rotation of the flap. There is a left and right trip provided with each auto-stop switch assembly. Each trip is differentiated from the other by the location of the pin at the bottom of the trip. The pin on the right trip will be on the left side of the flap when it is observed mounted on the cam wheel. The left trip will be the opposite. This arrangement allows the switch to pass through the trip when you wish to reverse the system the other direction. To restart the system after it has been stopped by the auto-stop switch, the switch arm must be returned to the center position. To do this, simply move the switch arm beyond the stopped position, rotate the flap up and allow the auto-stop switch to pass through the trip. This will allow the switch to rotate the flap when the system reverses the other direction. Be sure you have changed the direction switch to move the system in the opposite direction!

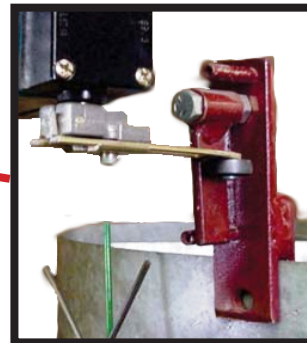
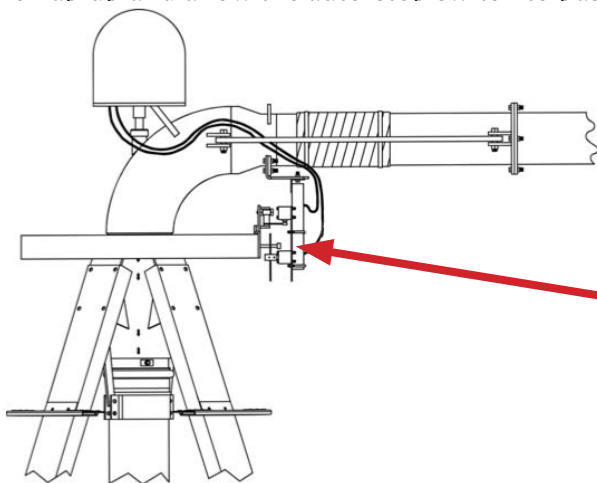

Cam Plate - Pivot Auto-Stop Option

The pivot auto-stop switch ramp fits onto a metal retainer plate bolted to the cam plate. To adjust the ramp, simply loosen the set screws and move the ramp to the desired point where the system is to auto-stop. Then re-tighten the set screws.

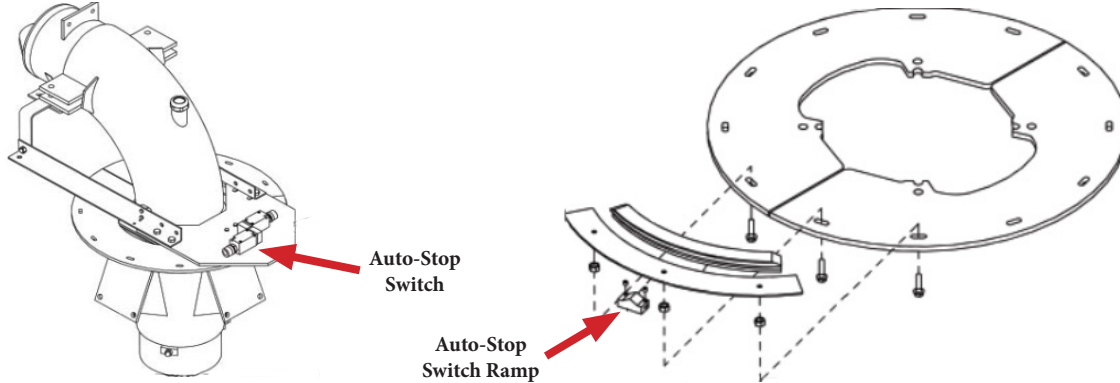

Tower Options



Warning

All auto-stop and auto-reverse devices require the construction of a barricade in the tower wheel track. The barricade should extend to the inside of the track to accommodate possible movement of the tower. The system may become shorter due to misalignment, but it cannot grow longer. See the barricade drawings on the following page.

Tower Auto-Reverse Option

Systems equipped with the tower auto-reverse option have the auto-reverse mechanism mounted on one of the outer towers. The tower auto-reverse switch is activated by a spring-loaded cable coupled to two auto-stop arms. As shown on the next page, when the tower moves and the auto-stop arm contacts a barricade placed in the tower wheel track, the cable moves, tripping the tower auto-reverse box, reversing the direction of the system.

The system can be reversed between barricades by placing the direction switch in the desired direction of travel and pushing the start button. It can then be restarted with the direction switch in the AUTO position. The system will continue to run in the direction that it was last moving. Two indicator lights have been placed in the inner panel door to indicate the direction of travel. After any idle period, the auto-reverse system must be tested to ensure proper operation. Visually check the lever and switch mechanism for damage. With the system running in auto-reverse, manually push the auto-stop arm opposite the direction of travel. The system should immediately reverse and the arm should return back to normal position. Repeat the process in the opposite direction to ensure the system reverses from both directions of travel. Pushing the auto-stop arm beyond the auto-reverse position will open the safety circuit and shutdown the system. The safety function must also be verified to ensure proper operation.

Tower Auto-Stop Option

The tower auto-stop switch is activated by a spring-loaded cable coupled to two auto-stop arms. As shown on the next page, when the tower moves and the auto-stop arm contacts a barricade placed in the tower wheel track, the cable moves, tripping the tower auto-stop switch. This action sends a signal to the main control panel, which disengages the starter contactor and stops the system.

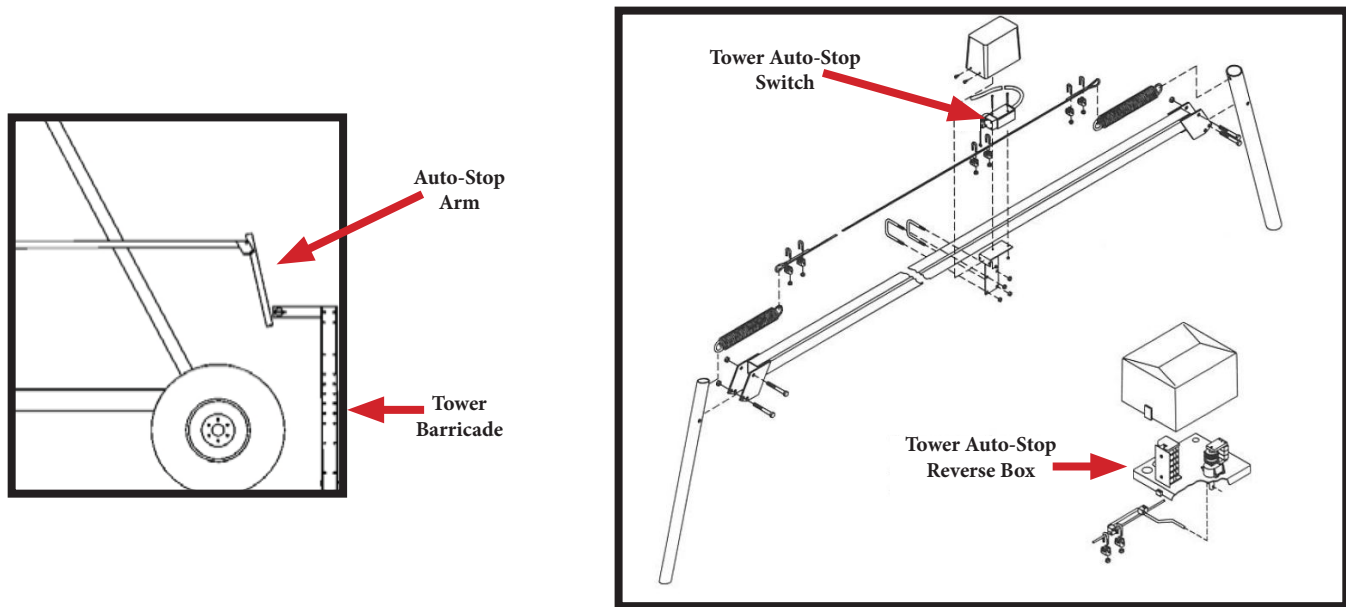

Tower Barricade

As stated earlier, all part circle systems are required to have an approved physical barricade to provide a safety backup in the case of an auto-stop or auto-reverse failure. Reinke Manufacturing provides two barricade options as shown below. One option is a portable barricade and the other is a stationary barricade. In both cases, it is critical that the barricade be properly placed and adjusted for reliable operation. Annual inspection of the barricade is part of the maintenance inspection.

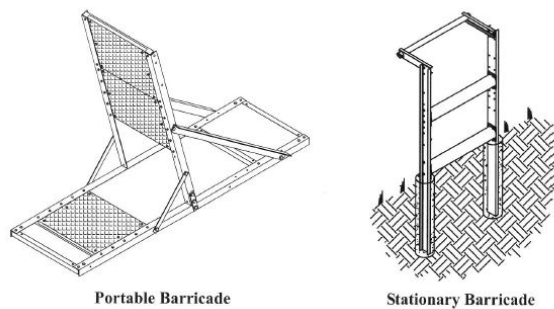

Note: These barricades are designed to be used on Reinke Systems, equipped with any auto-reverse or auto-stop option.

Warning *Great care must be taken to make sure the system alignment is maintained and the barricade remains centered on the wheel track.*

Proper Adjustment of the Reinke Stationary Barricade:

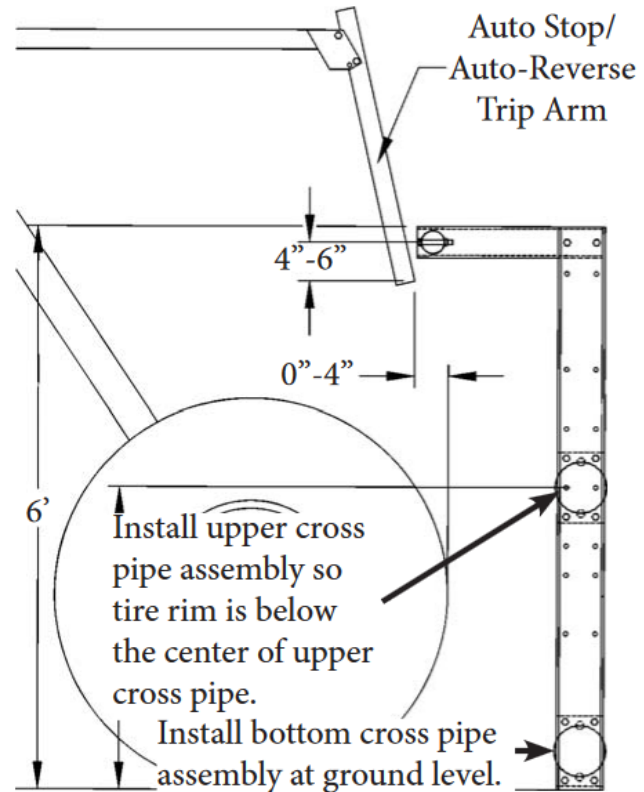

- The barricades are designed for use with systems having the following tire sizes: 11.2 x 24, 11 x 22.5, 14.9 x 24, 16.9 x 24, and 11.2 x 38.
- Center the barricade in the tower wheel track where the tower auto-stop or tower auto-reverse switch is mounted.
- The portable barricade must be adequately staked down on all four corners to prevent barricade movement. Stake size will vary depending on soil type and field conditions. The minimum stake size is 1" x 36" with cap heads. **The system warranty is void if the barricade is not adequately staked.**
- The stationary barricade channels must be set in concrete in a 10" diameter hole and 48" deep.
- The system must be kept properly aligned. Changes in system alignment will vary the distance from the pivot point to the wheel tracks. Severe misalignment may cause the tower to miss the barricade completely.

Disclaimer

Reinke disclaims any and all liability (including any liability pursuant to the Irrigation Systems Warranty) with regard to damage to the irrigation system, or to other property, or personal injury or death, caused by improper installation or maintenance of Reinke-supplied auto-reverse switches or tower barricades, or by use of customer-supplied barricades.

OPTIONS

Disconnecting Spans

This option allows one person to disconnect and reconnect spans from the system. This enables the system to continue operating through the remainder of the field, leaving the unused tower(s) behind. Use the following instructions when disconnecting a span.

 **Danger** *DO NOT attempt to disconnect or reconnect disconnecting spans until the Reinke main control panel disconnect switch, and all pump disconnect switches, are locked in the OFF position.*

1. Remove pin and lower leg stands. Replace pin to secure leg stands.
2. Disconnect the span cable receptacle connection, typically located below the tower control box, and plug into empty receptacle on disconnected span. Remove control rods.
3. Separate the drop pipes and insert the provided plug in the drop pipe on the tower side.
4. A winch (optional) or other device is used to lift the hook joint out of the receiver joint and lower the span. To lower or lift the span without the winch option, you will need equipment capable of lifting 2,500 pounds and something to support the disconnected span while not in operation.
5. Detach the cable from the hook joint.
6. Switch the A/C toggle switch on the tower control box at the disconnected span to "C" (end tower). When the disconnected span is reconnected, switch the A/C toggle switch on the tower control box located at the disconnected span to "A" (intermediate tower).
7. This process is reversed when the span is reconnected. Allow the auto-stop switch on the top of the disconnecting span to shut the system down for reconnecting.

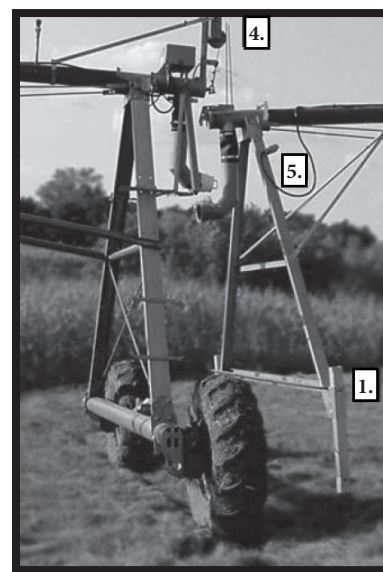

Chemical Injection

A flush time of at least ten minutes is typically recommended for center pivot systems. However, longer and low-gallon systems will require additional flush times. Allowances must also be made if the well and injection pump are not located at the pivot. A rough estimate for center pivot systems is one minute of flush time for each 100 feet of the center pivot system and mainline pipe. **THE SYSTEM WARRANTY IS VOID IF IT IS NOT FLUSHED AND MAINTAINED PROPERLY. CHECK AND ABIDE BY ALL LOCAL, STATE, AND FEDERAL LAWS AND REGULATIONS WHEN UTILIZING CHEMICAL INJECTION.**

Chemigation

Chemigation is the application of agricultural chemicals through center pivot irrigation systems. The main advantages to this technique are lower application costs and uniformity of application. The biggest disadvantage is the possibility of groundwater pollution. Some potential hazards are:

- Water flowing back through the chemical injection system, causing the chemical supply tank to overflow.
- Irrigation pumping plants shutting down from mechanical or electrical failures of the system, while the injection equipment continues to operate.
- Lack of a check valve on the irrigation line may result in the mixture of water and chemical siphoning back into the irrigation well and polluting the groundwater.

You can avoid these hazards by:

- Utilizing a check valve in the chemical injection line to stop the flow of water from the irrigation system into the chemical supply tank when the chemical injection pump is not operating.
- Interlocking the irrigation pumping plant and the chemical injection pump so if one stops, the other will also.
- The use of check and vacuum relief valves (anti-siphoning devices) on the irrigation pipeline.

Additional safety equipment could include a pressure switch in the injection line to detect a break in the line and a solenoid valve at the chemical tank outlet for a positive shutoff when the system shuts down. The injection system equipment should also include a calibration tube and the system should be calibrated before each application. Most injection systems include a built-in calibration tube, which allows the calibration to be re-checked periodically during application. (See illustration below.) See your local Reinke dealer for available chemigation systems.

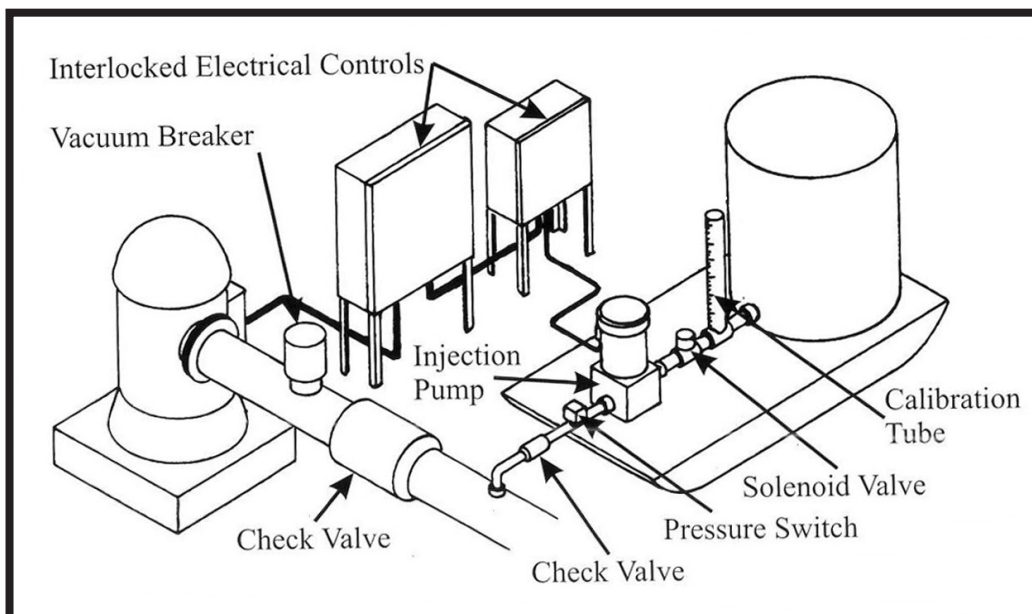

Fertigation

Fertigation is the application of fertilizers through center pivot irrigation systems. Fertigation is more popular on sandy soils. Sandy soils are more prone to leaching of fertilizers beyond the root zone. Fertigation allows for time release fertilizer application, thus reducing the potential for leaching and loss of fertilizer, and allowing the farmer to “spoon feed” crops. A word of caution: not all fertilizers are compatible with fertigation. Consult your fertilizer supplier before applying unfamiliar chemicals. Materials that should not be applied through irrigation systems include:

Anhydrous Ammonia: excessive nitrate loss, a calcium precipitate forms in the water.

Ammonium Polyphosphate: causes a precipitate to form in water.

Phosphoric Acid (or any acid): corrosive to steel and forms a precipitate in water.

See your local Reinke dealer for available fertigation systems.

Insectigation

Insectigation is the application of insecticides through center pivot irrigation systems. Always follow label directions! Allow time for a contaminated field to reach a safe level before re-entering the field. See your local Reinke dealer for available insectigation systems.

MAINTENANCE

All Reinke irrigation systems are designed for many years of use. However, studies have shown irrigation system reliability strictly depends upon good preventative maintenance. The following maintenance practices will help prolong the life of your Reinke system.

 **Danger** *DO NOT attempt to perform any maintenance procedures until the Reinke main control panel disconnect switch and all pump disconnect switches are locked in the OFF position. Electrical component troubleshooting and replacement should be performed by a certified Reinke Service Technician to ensure built-in safety features remain intact. Replace all protective guards and shields before restoring power to the system.*

Wheel Gearbox Maintenance

Non-Towable Gearboxes

The Reinke 50:1 wheel gearboxes use a good quality S.A.E. 85W-140 that meets or exceeds A.P.I. - GL.5 and IL.-21056 specifications. Change the oil after the first year of service and every three years thereafter. Fill the gearboxes so oil level is just above worm gear. Oil capacity is approximately one (1) U.S. gallon. Before and after each irrigation season, remove the drain plug just long enough to drain any condensed water.

 **Caution** *DO NOT overfill these gearboxes! Overfilling may result in seal damage.*

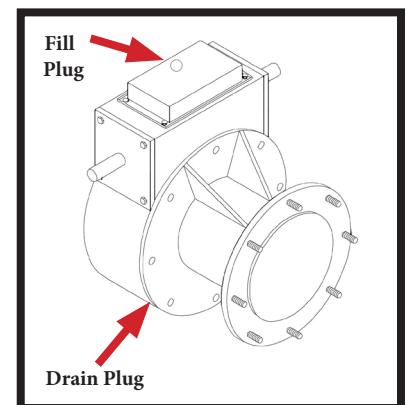

Center Drive Gearbox Maintenance

Three Phase (480 VAC) Center Drive Gearboxes

The Reinke helical center drive gearboxes use a good quality SAE 20W-50 multi-viscosity engine oil; or ISO 460 or EP 460 gear oil. Change the oil after the first year of service and every three years thereafter. Fill the gearboxes so the oil level reaches the threads of the oil fill hole. (See illustration below.) Oil capacity is approximately 0.4 U.S. gallon.

Caution *Do not overfill these gearboxes! Overfilling may result in seal damage. Before and after each irrigation season, remove the drain plug just long enough to drain any condensed water.*

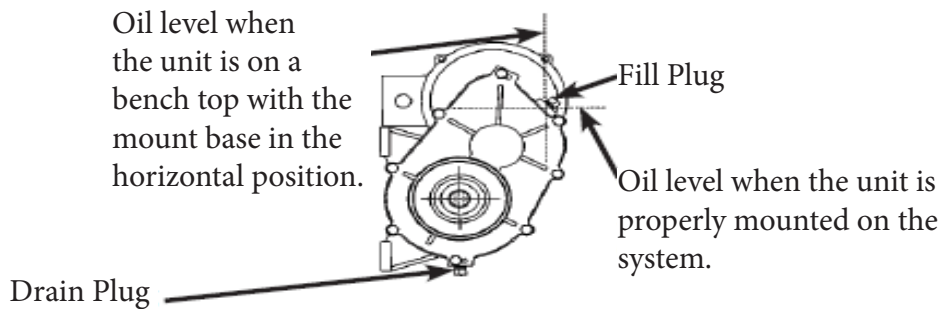

Single Phase (230 VAC) Center Drive Gearboxes

The Reinke 80:1 helical center drive gearboxes are composed of triple reduction 240 volt single phase 80:1 center drive, which is a complete integral gear and motor (P/N 112297) GR/MTR-UMC-CTR 80:1-06168-104A. These 80:1 gearboxes use a good quality SAE 50W or SAE 20W-50 multi-viscosity engine oil; or ISO 460 or EP 460 gear oil. Change the oil after the first year of service and every three years thereafter. Fill the gearboxes so the oil level reaches the threads of the oil fill hole. (See illustration on the right.) Oil capacity is approximately 72 ounces. Before and after each irrigation season, remove the drain plug just long enough to drain any condensed water.

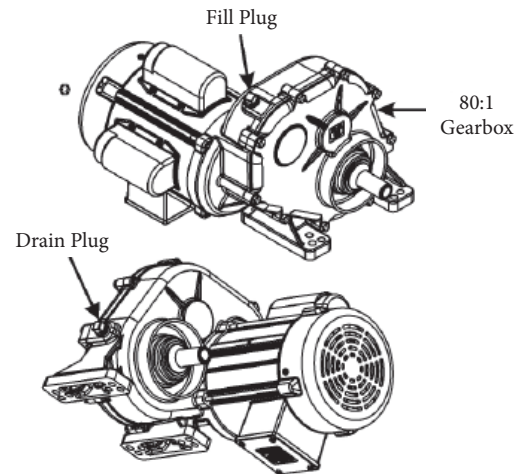

Caution *DO NOT overfill these gearboxes! Overfilling may result in seal damage.*

Initial and Preseason Maintenance

Before placing the system into service each season, check the following:

1. Make a visual check of all bolts in the system, making sure something has not become loose during the idle period. When the system has been newly installed, all the bolts should be checked with an end wrench to make sure they have been tightened by the erection crew. One loose bolt may cause serious structural damage.
2. Check the electrical boxes and wiring of the system to make sure the ground wires are secured and rodents or insects have not damaged the systems' mechanisms.
3. Flush the system. Place the disconnect switch in the OFF position. Only water is required for this procedure - the system does not need to move.

 **Danger** *DO NOT start the flushing procedure while the system is under water pressure. Removing sand trap caps while the system is under pressure can cause personal injury or death.*

Remove the sand trap cap and pump water through the system. This will flush out any foreign material that might plug the sprinkler heads or sprinkler valves. This is particularly important on newly installed systems, because of possible straw, dirt or any other material that may have accumulated in the pipe during erection. After the sand trap cap is back in place, pump water through the system and check the sprinklers for proper operation. The arc travel of the end gun should be set as the diagrams show on page 15. Also, check the system water pressure to see if it is operating at the proper pressure. If the water pressure has fallen, your pump may need adjustment or repair, or after time, the sprinkler head nozzles may be worn. These problems will reduce the uniformity of water application and should be corrected. If a sprinkler nozzle is replaced, make sure the new one is the same size. After flushing the system, check the function of the low pressure drains by pushing each one upward in a rotating motion. Low pressure drains are located on the bottom side of each hook joint, the last tower top, and on the end boom pipe.

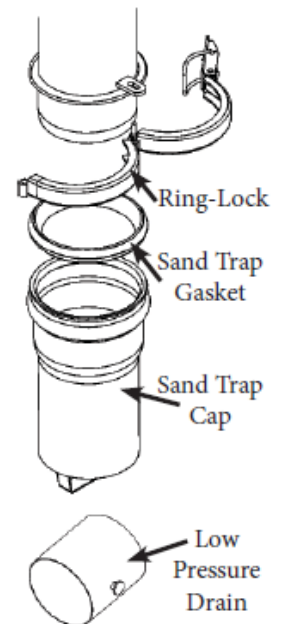

4. Grease fittings are located on the pivot (8 each), at any optional steel u-joints (1 each) and on any towable gearboxes (2 each). These fittings should be greased with good quality grease.

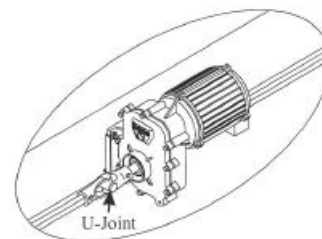
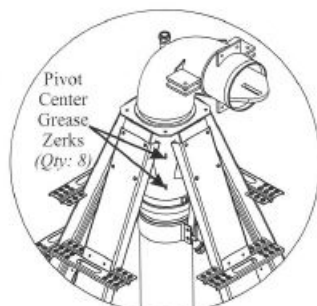

5. All automatic controls such as auto-stop, end gun, tower auto-stop, and tower auto-reverse should be cycled to check for proper operation. Consult your local Reinke dealer, or authorized service technician, for assistance.
6. If a booster pump is installed on your system, it should be inspected for proper operation. A second person should be located near the end boom. Turn the percent timer to zero and, with power to the system, press the start button. When the system is at normal operating pressure, turn the end gun switch to the ON position and check the phasing of the booster pump. If you were able to view it from above, you would see that the pump shaft would be turning in a clockwise direction when running. Operating the pump backward can damage the pump. When the end gun switch is OFF, the booster pump should be OFF. If the phasing needs to be changed, contact your Reinke dealer or service person.
7. Check the oil level in the center drive and wheel gearboxes. Water condenses in the gearboxes and should be drained. The water may be drained by loosening the drain plug on the bottom. When the plug is removed, if there is any water, it will be the first to drain out. Gears should be filled to the specifications on pages 23-24.

 **Caution** *DO NOT overfill these gearboxes! Overfilling may result in seal damage.*

8. Tire pressure should be maintained according to the chart shown here. Also, inspect the tires for impending problems (cuts, breaks, etc.).
9. Wheel lug nuts should be torqued to 125 lb-ft.
10. Main control panel switches should be cycled and checked for proper system operation. (See pages 8-11.)
11. If the system utilizes generator belts, check them for proper tension. (See illustration below.) Before starting the engine, remove any rodent nests from the engine fan cover.

Reinke Tire Inflation Chart Based on Manufacturer's Recommendations	
<i>Tire Size</i>	<i>Max. Load & Infl. (lbs @ PSI)</i>
11R x 22.5 (Recaps)	4000 @ 52
11.2 x 24	3900 @ 35
11.2 x 38	4410 @ 23
13.6 x 38	6965 @ 29
14.9 x 24	4640 @ 16
16.9 x 24	7215 @ 23

 **Caution** *If the generator rotation is ever reversed later, the system will be out-of-phase. Call your dealer or service person to correct the phasing problem if you plan to operate the generator in the opposite direction.*

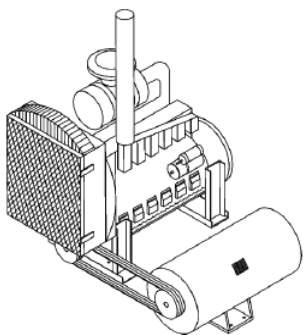

Note: The generator warranty requires that all combustion engines coupled to a generator, driving the system, must have a governor, a tachometer, and a safety load meter. The generator and system controls will be damaged by over or under engine speeding.

Maintenance During Season

1. Periodically check the built-in voltmeter on the main control panel inner door and make sure it reads 456-504 VAC, 60 HZ (380-420 VAC, 50 HZ) on 480 VAC systems or 230-250 VAC, 60 HZ on 240 VAC systems. At no time, should the operational voltage read outside these parameters. If it does, find out why and correct it. This will prevent possible damage to the drive motors and other electrical components. If your system uses a generator, excessive voltage indicates it is running over speed. This can damage the generator and the system's controls. Also check the tension of the generator drive belts. Loose belts can cause slippage and low voltage output may result. Exercise caution if you manually check your system for proper voltage using a multimeter.
2. Grease fittings are located on the pivot, at any steel u-joints, and on any towable gearboxes. These fittings should be greased approximately three times a season, depending on use, with good quality grease. (See illustrations on pages 23-24.)
3. The system should be inspected periodically. Look for under-inflated tires, oil leakage from gear boxes, structural damage from the result of severe storms, etc.
4. Periodically check the alignment of the system. The system is initially aligned when it is erected. Alignment is a very important factor in the operation of an irrigation system. A misaligned system develops very high stresses which could cause structural damage and reduced center drive and wheel gearbox life. If the alignment of the system needs to be reset, it is done by turning the adjusting screws on the control yoke located at each tower. It is better to turn both screws (in opposite directions) rather than making an alignment adjustment with one screw. The illustrations below show which way to turn the screws for the desired alignment. The descriptions for turning the screws are given for someone looking toward the end of the system.
5. **Reinke Manufacturing recommends that the alignment and safety switches be replaced after 10 years of service to ensure reliable system operation.**

Leading Bow

A leading bow can cause problems by creating extreme tension or pull that could cause structural damage.

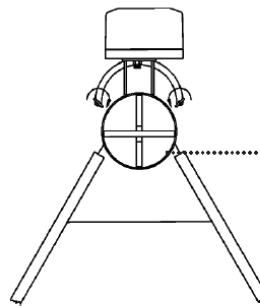

Turn thumbscrews as shown above to correct alignment if the tower is ahead with the system running in the forward direction or behind running in the reverse direction.

Reverse Bow

A reverse bow is very critical as it causes a compression of the entire system. When the spans are compressed, they tend to lose their inherent strength.

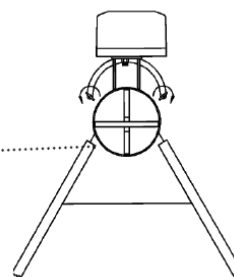

Turn thumbscrews as shown above to correct alignment if the tower is behind with the system running in the forward direction, or ahead running in the reverse direction.

When the system is correctly aligned, it will have a slight bow with the center tower leading. When the direction of travel is changed, the system should bow the same amount only in the opposite direction. If a tower becomes stuck, or some other problem causes it to stop, the towers toward the end of the system will continue to run until the misalignment safety circuit shuts the system down. This results in a bend in the system at that tower. See the drawing below. If the lagging tower is brought into alignment by continuing to run in the same direction, the outer towers will be forced outward to compensate. This causes considerable stress and possible damage to the system's structure. Therefore, after the problem has been corrected, run the system in the opposite direction so the outer towers run back even with the stalled tower. Then it is safe to operate the system in the desired direction.

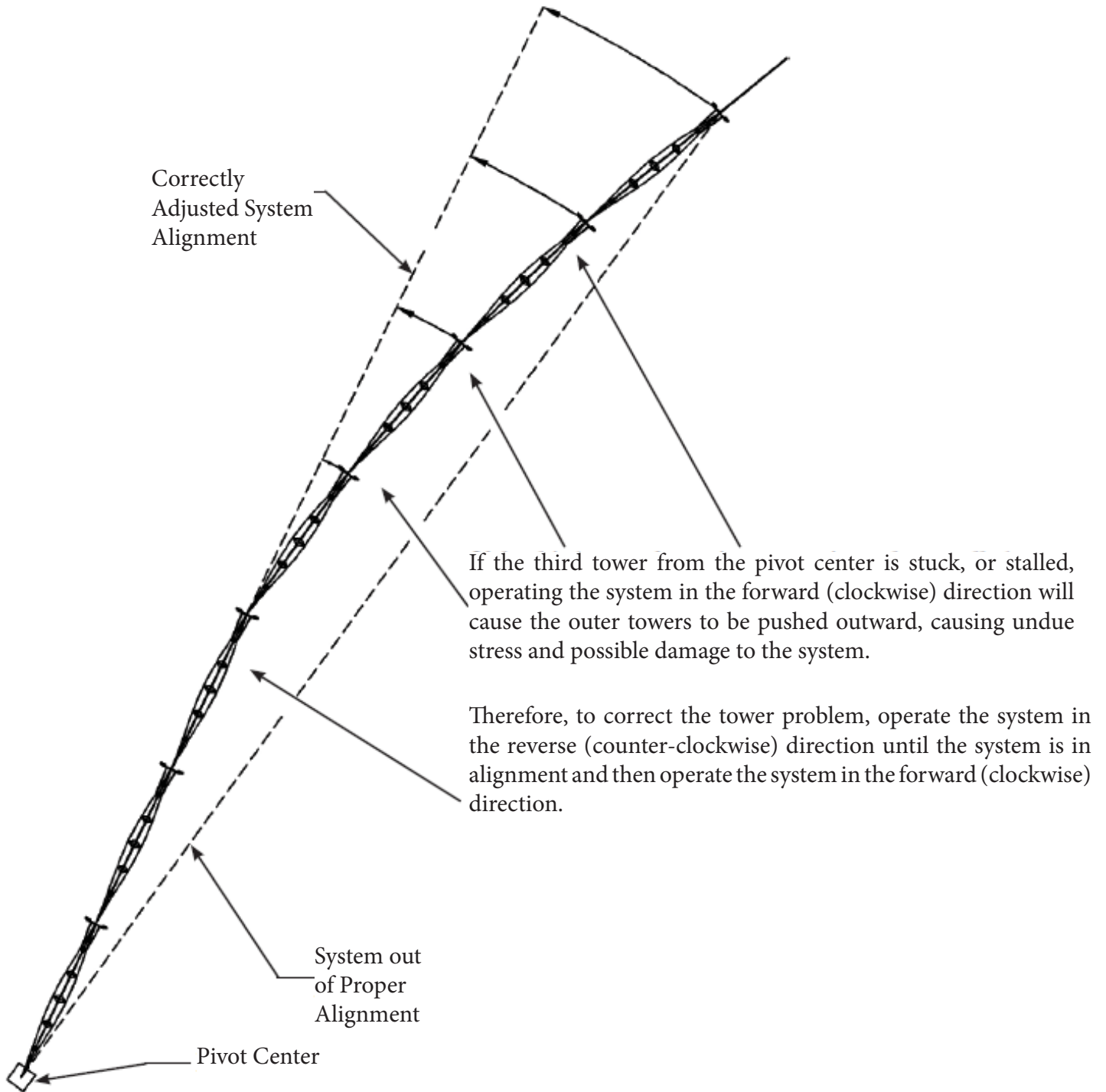

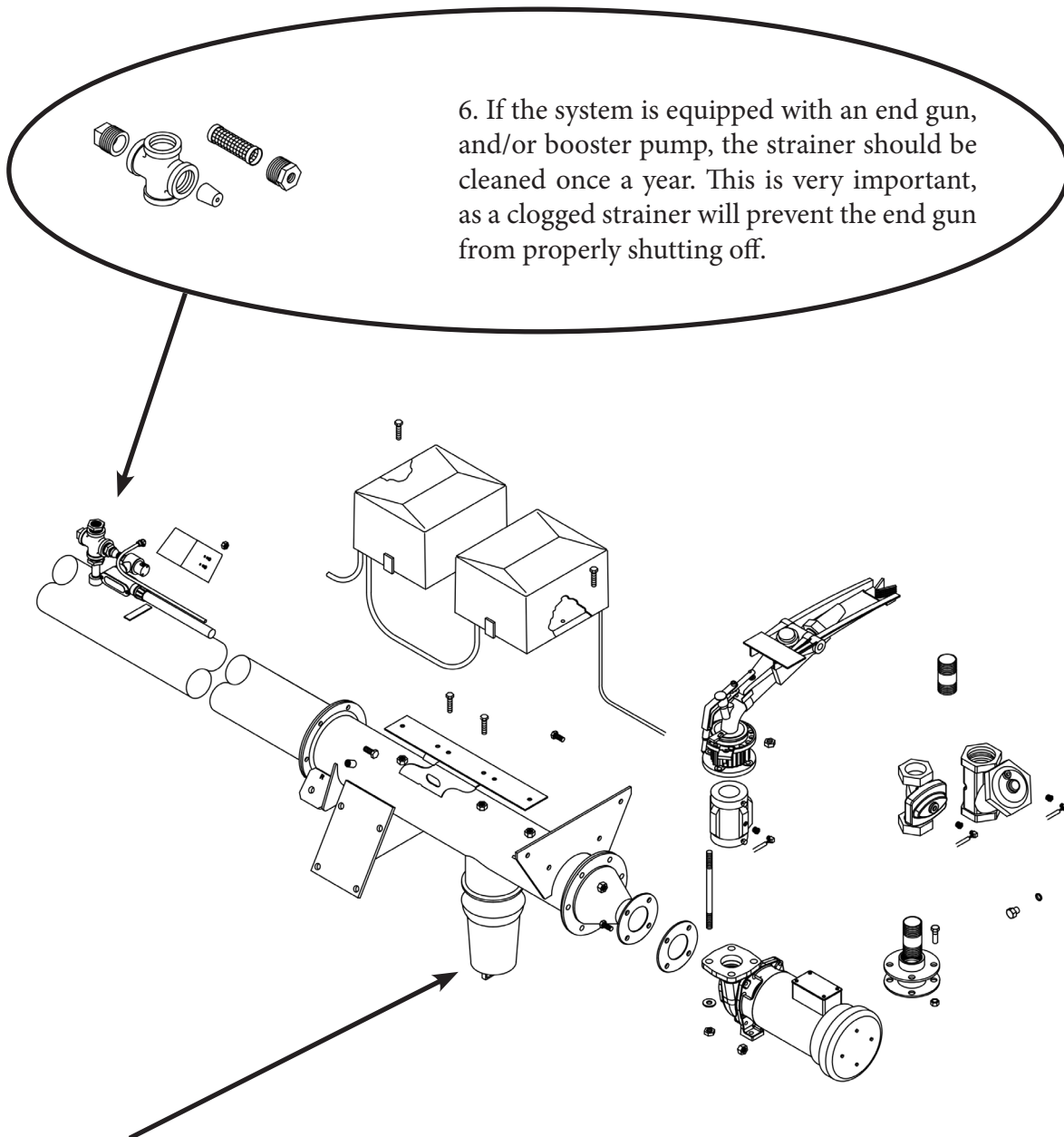

7. Check the sand trap regularly for accumulation of sand or debris. If the sand trap is full, clean it out with the trap off, start the pump to flush the system. (See instructions on page 25.) Replace the trap once it has flushed. The sand trap may need to be cleaned weekly if the water supply is dirty or the well is pumping a large amount of sand.

Winterization Procedure

1. Park the system on a smooth surface, out of the wheel ruts. Also, park the system parallel to prevailing winds to avoid, as much as possible, the effects of damaging winds.

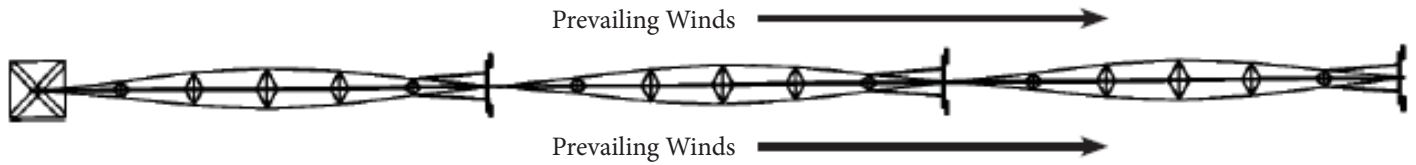

2. Flush the system following the same instructions found on page 25.
3. Check the low pressure drains by pushing each one upward in a rotating motion.
4. Grease fittings are located on the pivot (8 each), at any optional u-joints (1 each). These fittings should be greased with good quality grease. This will prevent corrosion and decrease the amount of moisture accumulation during the idle season.
5. Check the oil level in the center drive and wheel drive gearboxes. Water condenses in the gearboxes and should be drained. The water may be drained by loosening the drain plug on the bottom. When the plug is removed, if there is any water, it will be the first to drain out.

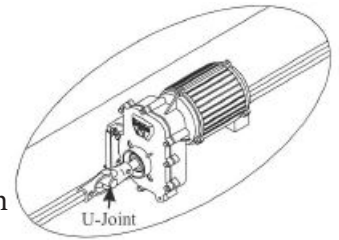

Caution *DO NOT overfill any of these gearboxes! Overfilling may result in seal damage. Gearboxes should be filled to the specifications on pages 23-24.*

6. Protect the drive train components from damage if livestock will be pastured during the off season.
7. Sometimes water is trapped between the well and the pivot bottom elbow. Some means of drainage should be installed (if none exists) on or near the check valve and in the underground pipeline.
8. Generator power cords, plugs, and receptacles should be protected with waterproof covers. Wrap the cords up and hang them up off the ground.

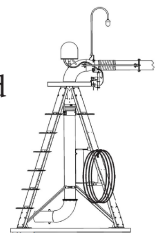

Swing Arm Maintenance

The SAC/SSAC has multiple grease zerks. Greasing the machine should occur annually, at the very least.

There is a grease zerk located on the leg above the wheel on the swing tower. Add grease until it starts coming out of the bottom of the leg. There is a zerk on each leg of the swing arm.

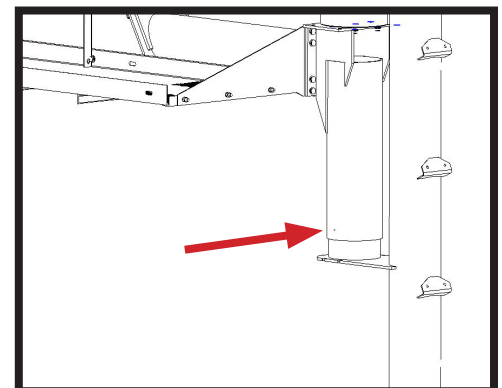

The next area to be greased is on the steering gear of the swing arm. There is one on each leg. Because the gear is on its back, as opposed to standing up, there is a grease zerk installed into the output shaft area. DO NOT overfill. There is also an expansion chamber that is installed to keep the pressure of the oil from leaking out.

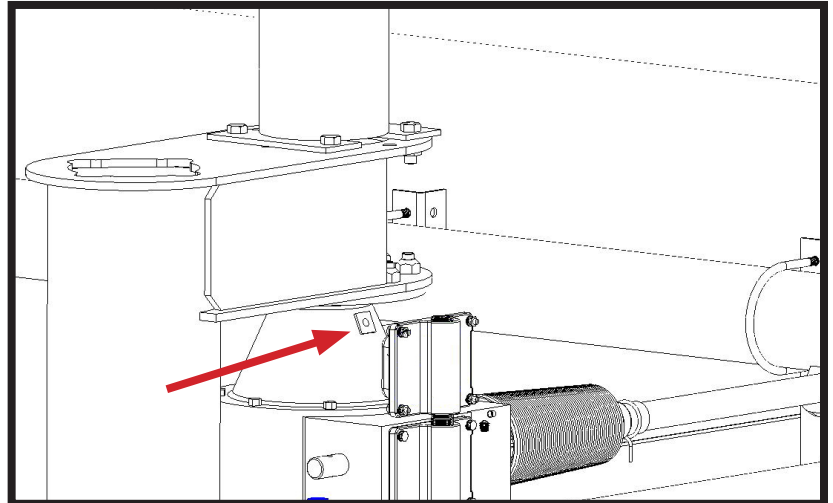

The last two grease zerks that are on the swing arm are located at the joint between the swing span and the hinge tower. They keep the ball greased so that the swing span can walk smoothly.

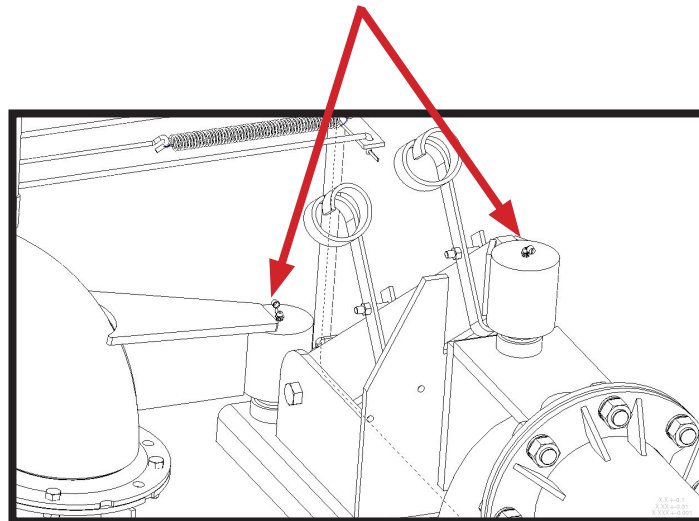

One post-season maintenance item on the swing arm is the elbow that gets the water from the parent machine to the swing span. The “U” pipe has a low pressure drain that can stick because the pressure never gets low enough to release the drain. Once the irrigation season is over, it is good practice to push the drain up and allow the water to drain so that it does not freeze and damage the system.

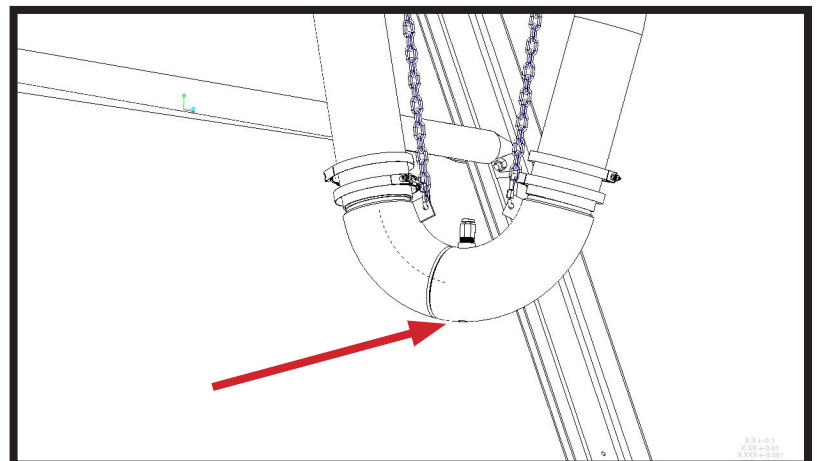

TROUBLESHOOTING



Danger *Before troubleshooting, turn the power at the main control panel OFF and LOCK in position. If you attempt to repair your system and are uncertain of your methods, contact your authorized service person. If a repair is made, replace all protective guards and shields before restoring power to the system.*

As a system is being checked for errors, make notes of each situation. This will help to explain the possible problem, and what measures have been completed so far to correct it. The items on the following checklist should be used as a guideline, before contacting a service technician:

- System Serial Number including Model Number
- Optional Equipment (Auto Reverse, Auto Stop, Frost Control, etc.)
- Location of system in the field, and approximate time when the system shut down
- Alignment of the system
- What has been done since the system shut down

PROBLEM I: System will not continue to run when you release the start button.

Possible causes and solutions:

- Set the generator Start/Run switch to the START position.
- Set the pressure override switch to the BYPASS position.
- Set the park override switch to the BYPASS position.
- Make sure the system is not against a tower barricade.
- Check to see if the system is out of line. Check the alignment making sure a stuck tower, a flat tire, or broken u-joint has not caused the system to become out of line.
- A tower does not move. The center drive motors contain an internal overload switch that resets after shutdown. Contact your Reinke dealer or service technician if the problem persists.
- The tower auto-reverse system fails. Check the tower auto-reverse mechanism or contact your Reinke dealer or authorized service technician.

PROBLEM II: System shuts off in line.

Possible causes and solutions:

- Incoming power voltage surges or low voltage may cause the system to shut down.
- If a generator is used, check the belts to make sure they are tight. Make sure the motor is not overheating and shutting off.
- Check to see if the auto-stop switch is against a trip on the cam wheel or the tower is against the barricade. Adjust the switch trips or reverse the system away from the barricade if necessary.
- With the main disconnect switch in the OFF position, check the fuses in the main control panel with an ohmmeter. If no continuity is found in a fuse, replace it. Call your Reinke dealer or authorized service technician if you continue to blow fuses.
- Check fuses in the generator with an ohmmeter. Replace if necessary.

PROBLEM III: System shuts off out of line.

Possible causes and solutions:

- Check the tower where the misalignment occurs to see if the tower is stuck. If this is the case, reverse the system until it is back in line, then add rock or something to the wheel track so the tower can continue on its path.
- Check for flat tires, damaged gearboxes, or broken u-joints where the misalignment occurred.

PROBLEM IV: System will not move in either direction.

Possible causes and solutions:

- No 480 VAC or 230 VAC power to the system.
- A fuse is burned out in the main control panel.
- The start button is defective.
- The main control panel disconnect switch is bad.
- The direction switch is defective.

PROBLEM V: Sprinklers on the swing arm are ON when they should be OFF.

Possible causes and solutions:

- Check for any bad valve tubing. Replace any that are broken or cracked. Do not stretch the tubing tight between connections, it will shrink over time.
- Check each of the coils in the valve box for resistance. They should read 170 to 180 ohms.

 **Caution** *Be sure the power is turned OFF at the main control panel.*

Service Record														
Date	Hour Meter				System Servicing							Parts Replaced		
	Mo./Day/Yr.	Hr. Reading	Grease	Fill Gears	Tire Pressure	Sand Trap	Sprinklers/Drains	Generator	Engine	Tower No.	Flat Tire	Wheel Gearbox	Center Drive	HT Couplers



Water Application Record

Date Mo/Day/Yr	Hour Meter Reading	Percent Timer Setting	Well Gallonge gal./hr. (gpm x 60)	Well/ System Inches Applied	Inches of Rainfall	Yearly Total Inches to Date



Reinke Manufacturing Co., Inc.
1040 Road 5300 Deshler, Nebraska 68340
U.S.A. Telephone: 402-365-7251
Fax: 402-365-4371